

DESPIECE

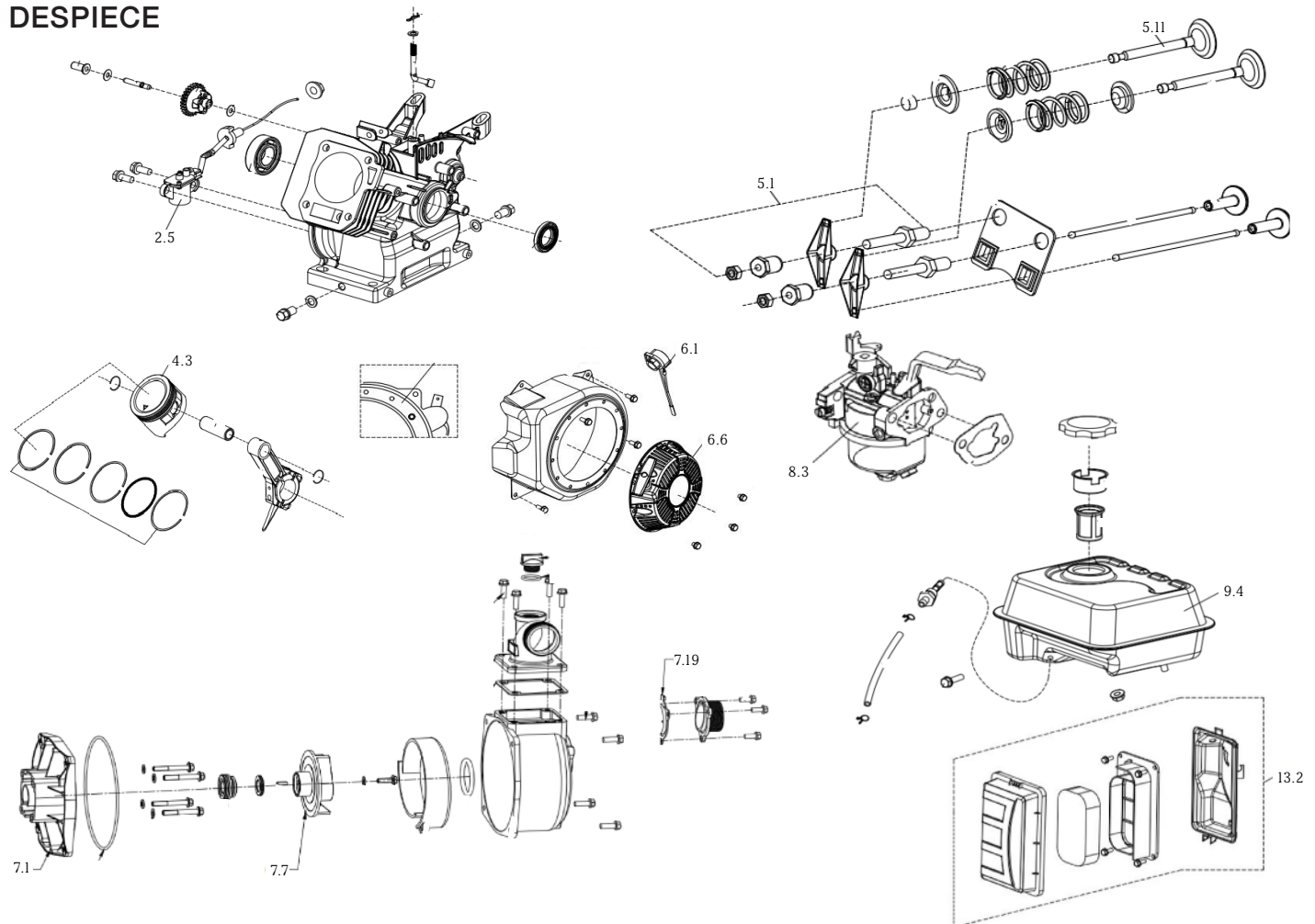

TABLA DE ESPECIFICACIONES

POS	REFACCIÓN	EWBG2-500F	EWBG3-1000F	CÓDIGO
2.5	Sensor de nivel de aceite	✓	✓	R-EWBG2-3/SNA
4.3	Pistón	✓	✓	R-EWBG2-3/PST
5.1	Balancín	✓	✓	R-EWBG2-3/BCN
5.1	Válvula de admisión	✓	✓	R-EWBG2-3/VLA
5.11	Válvula de escape	✓	✓	R-EWBG2-3/VLE
6.1	Interruptor de encendido/apagado	✓	✓	R-EWBG2-3/SW
6.6	Arrancador de retroceso (motor)	✓	✓	R-EWBG2-3/SAR
8.3	Carburador	✓	✓	R-EWBG2-3/CBR
9.4	Tanque de combustible 3.6L	✓	✓	R-EWBG2-3/TAN
7.1	Cuerpo de bomba	✓	✓	R-EWBG2/CB R-EWBG3/CB
7.7	Impulsor	✓	✓	R-EWBG2/IMP R-EWBG3/IMP
7.19	Válvula check	✓		R-EWBG2/VCHECK
13.2	Conjunto Filtro Aire	✓	✓	R-EWBG2-3/CFIL